

HAND TRAIL the missing Link!

BETWEEN HALTER AND SPORHORSES

by Elisabeth Chat ■ photos by Christian Kellner, Doris Dobretsberger, Helmut Chat, Marlies Trap,
Drawing of Gaits AQHA 2008, patterns Barbara Henge

In the last few years Hand Trail is booming all over Europe. The intelligent, clever and humanfriendly Arabian Horse is perfect for this “new” Sport and love to do this with his master. Up an age of one year the horses can participate. All ages of handlers from 8 years up can compete. Those they can’t ride, or do not like, have a good way to work their Arabian Horses by hand. Hand Trail can be the beginning of training for a young horse, young by age or

by education.

The classes in competitions are large, over 20 horses!

The rules in the ECAHO rule book “GREEN BOOK” are clear and easy to follow.

There are three mandatory obstacles and several obligatory ones.

A nice trail pattern should include minimum six obstacles.

Beginning with the low leveled and not so difficult Hand Trail



BRIDGE Eric Blaak



BRIDGE Diego el Bri



BRIDGE Nedschd Malik

pattern like Novice ones, now the handlers are asking for more and more difficult ones. The discussion in the ECAHO Sportcommission is now on the point to have like in Ridden Trail also in Hand Trail three levels: Novice, Advanced & Master. The judging is following the Ridden Trail. The good relationships and harmony with the handler is added in the total score. The horse should practice all obstacles in a quiet and well accepted way. In that gaits, following the drawn Hand Trail pattern. Not too

slow, not in a hurry, not nervous or afraid. The good Trail horse is able to check the obstacle and work through. The mandatory obstacles are: Bridge, Gate, minimum four poles or logs walk, trot or lope over and Back through. All others are obligatory obstacles. The gaits between the obstacles have to be shown as described and the correct line of the pattern has to be shown. Two examples of Hand Trail patterns:

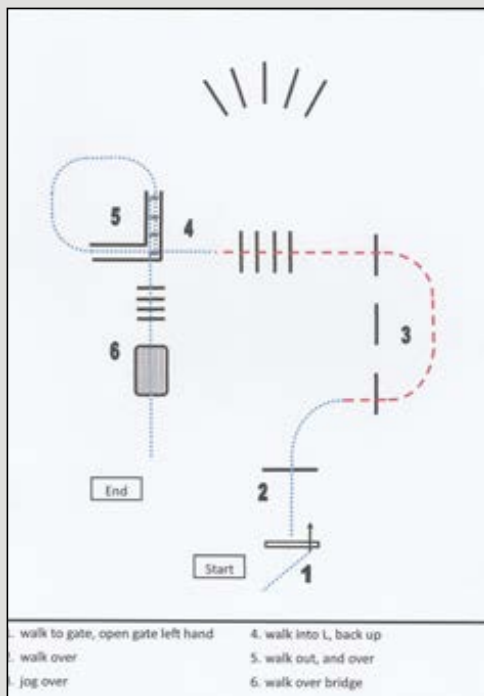

Hand TRAIL Pattern simply

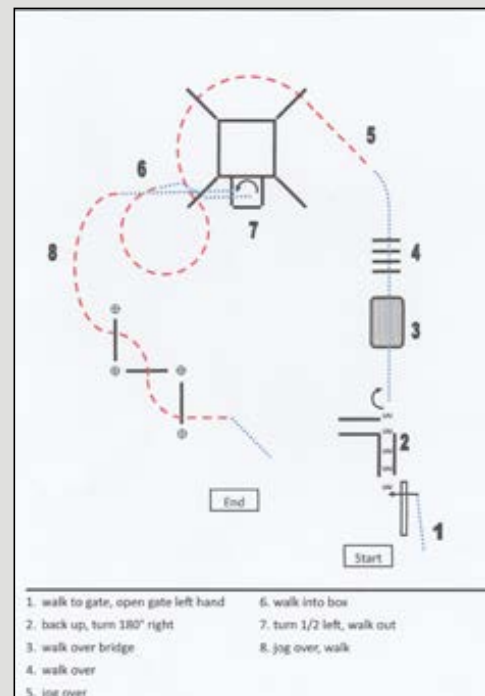

Hand TRAIL pattern medium

WALK OVERS

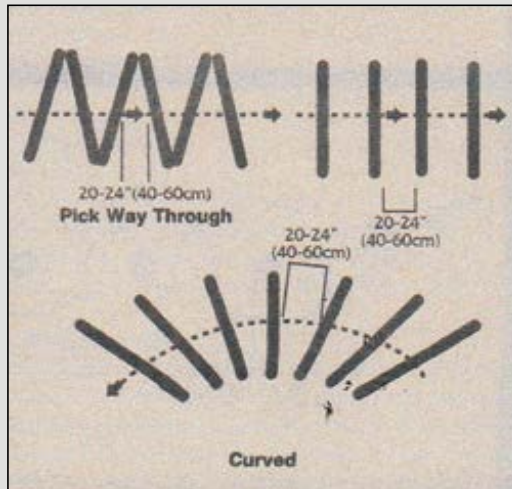

WALK OVER POLES LR El Fuego

The obstacles have no numbers, the handler has to remember the pattern, doing wrong is a disqualification.

The size and distance between the poles or obstacles you will see in the drawings of obstacles.

The Gate can be a normal gate of a fence or a rope gate. This should be not wider than 2 m

Poles can be elevated, but never able to roll away.

Penalties will be given for kicking on a pole, pushing the pole away or ruin the obstacle.

There is also the chance for doing very well to receive Plus Points. The horse will start with 70 points the penalties will be deleted and the plus added.

The Trail pattern can also include some combined obstacles. The whole Trail should not take too long in time 5-6 minutes is a



GATE Livia Audic & Probat al Siam



GATE Clemens Dubois & Azureene de Cure

TROT OVERS, LOPE OVERS

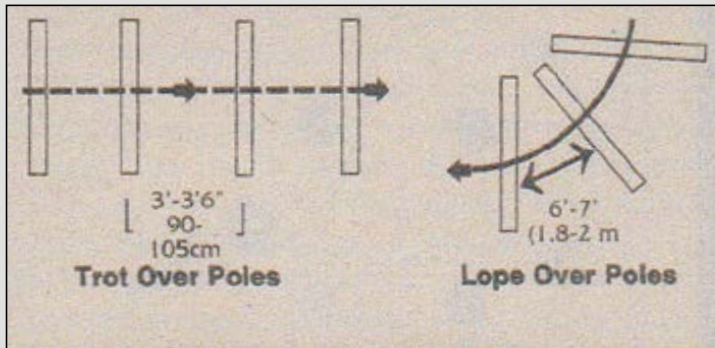

TROT OVER POLES Clemens Dubois & Azureene de la Cure



TROT over poles Sissi Chat & Tecumseh



Inspection of Handtrail & Trail pacours by the participants

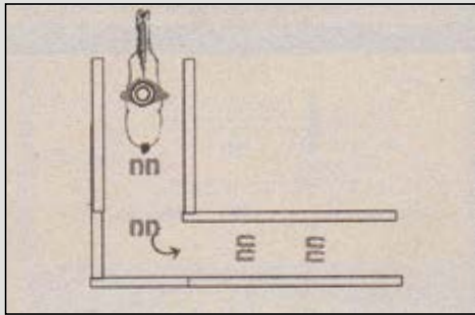

VARIATION OF L BACK THROUGH

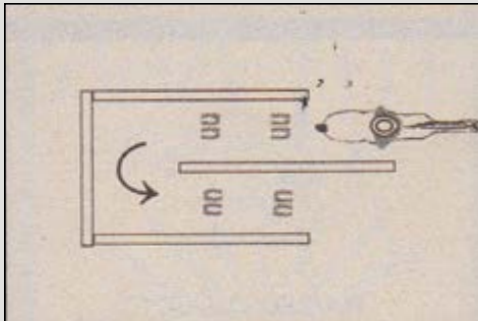

BACK THROUGH Livia Audic & Probat al Siam

BACK THROUGH AND AROUND THREE MARKERS

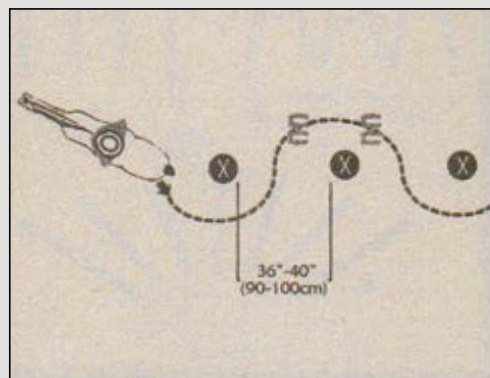
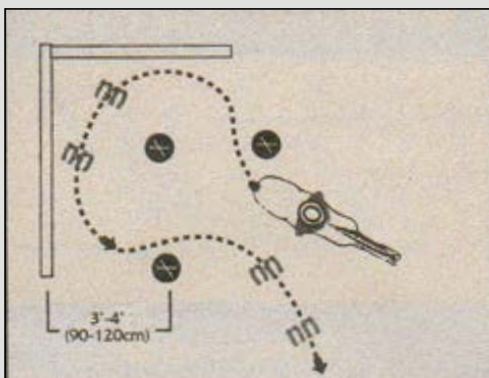
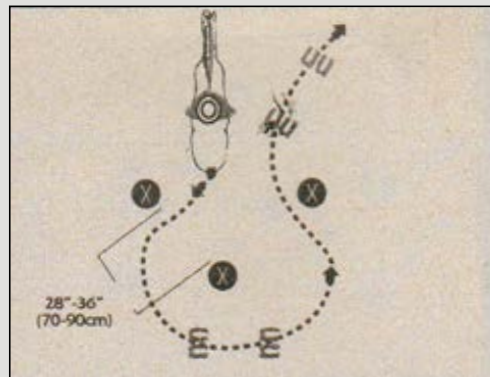
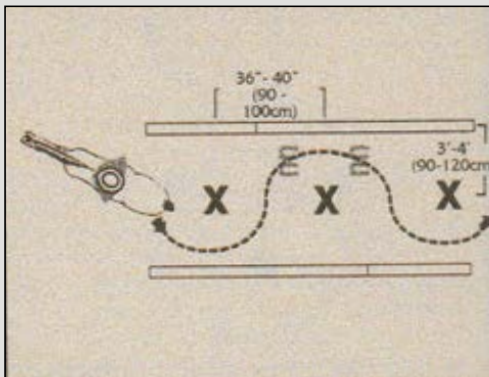

VARIATIONS OF SIDEPASS

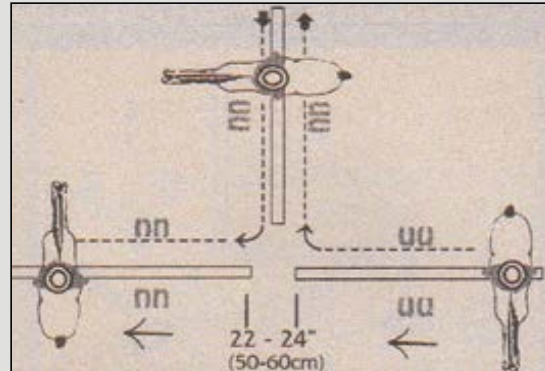
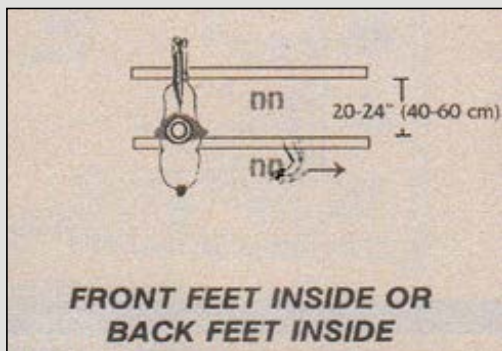
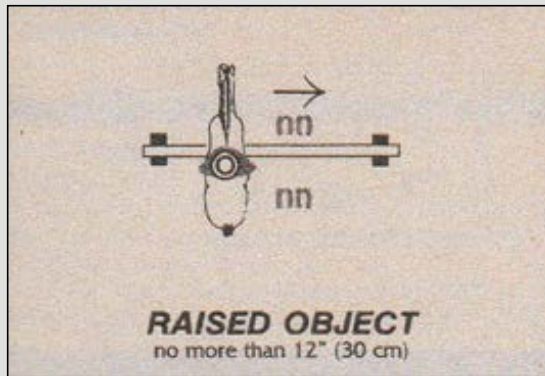
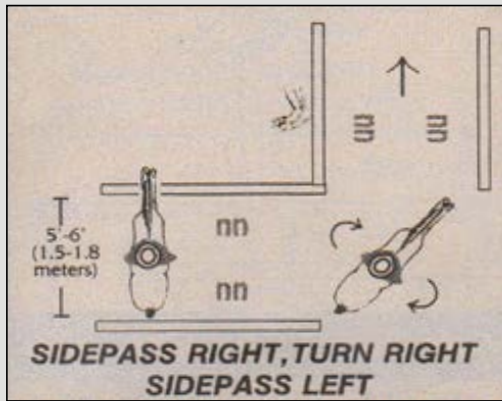

TROT OVERS, LOPE OVERS & WALK OVERS



COMBINATION walk over Poles & Bridge Mario Matt & MM Sandrine

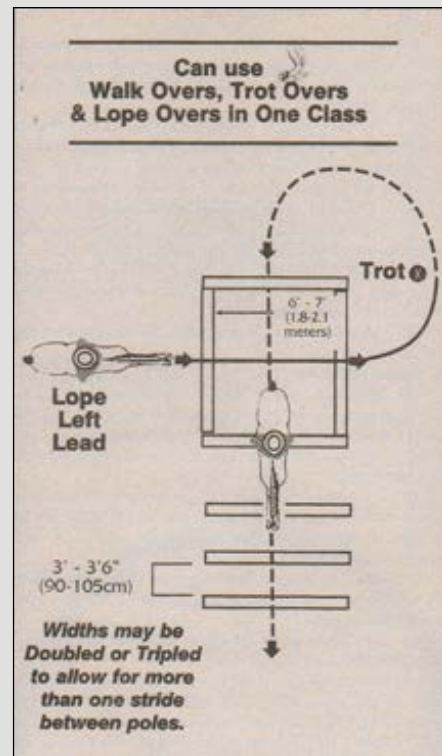



Box right turn Eric Blaak



Box left turn Sissi Chat & Tecumseh

good average time for a whole pattern.

After every participant the obstacles have to be inspected by the judges, repaired and give the start free.

The drawn pattern should be announced in time in front of the class. The handlers are allowed to inspect the whole parcours together with the judges, without horses, in front of the class.

Outfit of Horse: Fitting Halter and lead max 2m, leather recommend. Chain and whip possible, it is not allowed to touch the horse by hand or whip.

The handler can wear either classic or western competition cloth or Halter dress. □



TROT between obstacles, Rebecca Farell & MM Nevio



OUTFIT Mario Matt & MM Santana



OUTFIT Sissi Chat & Tecumseh



Prizegiving ceremony Livia Audic 8 years with Probat al Siam



Winners of Hand Trail Cup 2019